



National Kaohsiung
CENTER FOR THE ARTS

WEI WU YING 

衛武營 國家藝術文化中心

國家表演藝術中心 National Performing Arts Center

音樂廳

CONCERT HALL

技術製作資訊

Production Technical Information

Table of Contents

0 General Information	1
0-1 National Kaohsiung Center for the Arts (WEIWUYING)	1
0-2 Concert Hall	1
0-3 Traffic Information	2
0-4 Contact Information	2
0-5 Stage door	2
0-6 Auditorium / Seating	3
0-7 Concert Hall Plan	5
0-8 Concert Hall Section	7
1 Stage	8
1-1 Stage	8
1-2 Hoisting	8
1-3 Stage Elevation Platform	9
1-4 Acoustic Panel	9
2 Lighting	10
2-1 Lighting System	10
2-2 Lighting Instrument	11
2-3 Accessories	12
2-3 Lighting Circuit	15
2-4 Portable Lift	18
2-5 Additional Power Supply	18
2-6 House Light / Working Light / Blackout	18
3 Audio/Video Systems	19
3-1 Audio Facilities	19
3-2 Control Room	19
3-3 Stage Manager' s Console	19
3-4 Machine Room	19
3-5 Microphone	20
3-6 Communications	20
3-7 Locations of Communications	21
3-8 Stage Cameras and Video Surveillance Systems	21
3-9 Paging Systems	21
4 Backstage	23
4-1 Dressing Room and Green Room	23
4-2 Orchestra Facilities	23
4-3 Pianos (shared between four <i>venues</i>)	23
4-4 Loading Dock/ Scenery Shipping Path / Loading Flow	24
4-5 Other Facilities	26

更新日期:2018/09/26

0 General Information

0-1 National Kaohsiung Center for the Arts (WEIWUYING)

CENTER FOR THE ARTS, ARTS FOR THE PEOPLE , National Kaohsiung Center for the Arts will become one of the important theatre complexes of the international art field. It include four performance blocks, the 2,260-seat Opera House, the 2,000-seat Concert Hall, the 1,254-seat Play House and the 470-seat Recital Hall.



0-2 Concert Hall

The Concert Hall features a unique vineyard style. The unique design allows audience at various heights to enjoy the same optimal acoustic and visual effects, taking care of each and every member in the audience. The seating arrangement encircles the stage, bringing the audience closer to the stage for more intimate experiences with conductors and performers.



0-3 Traffic Information

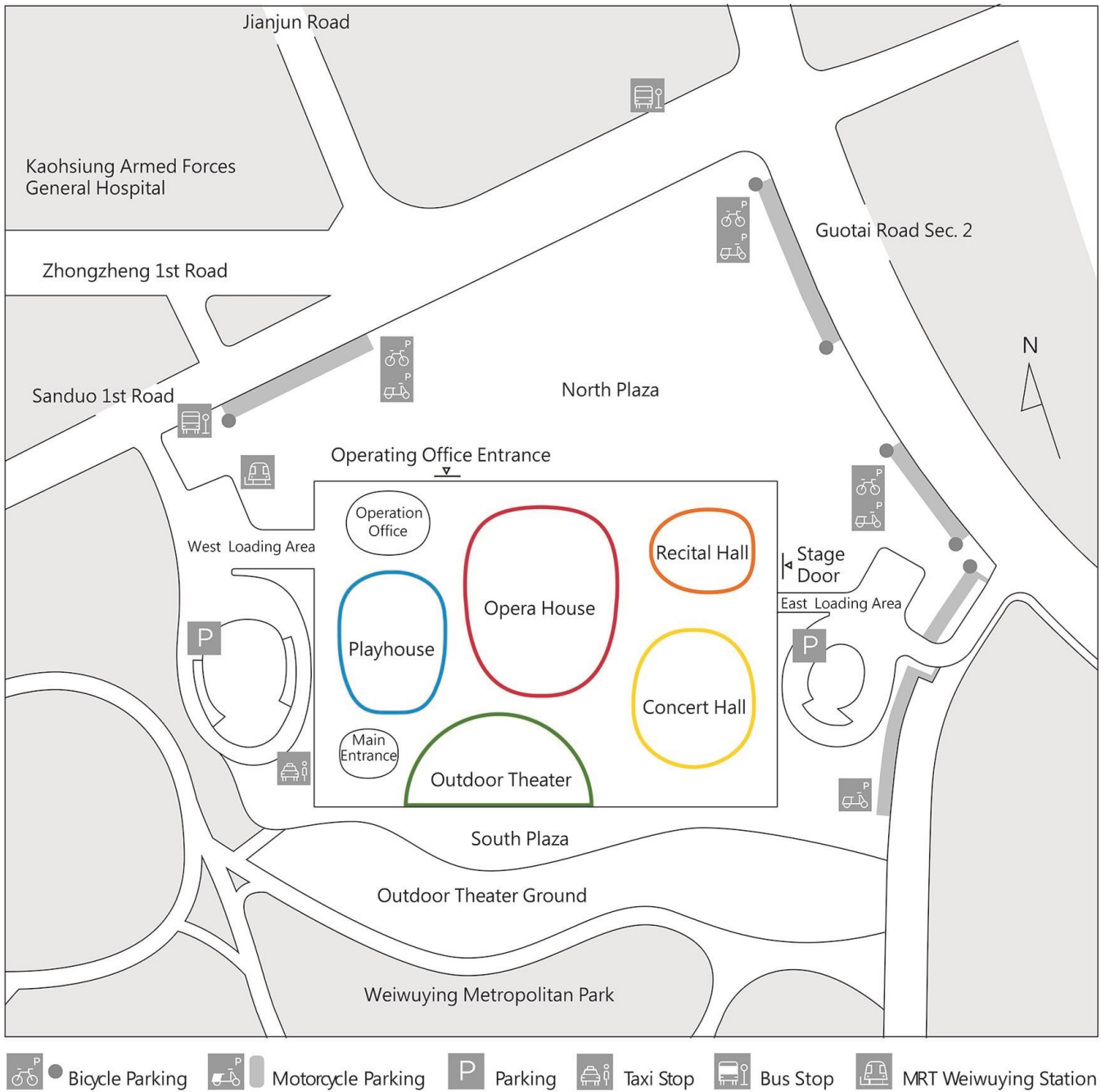

0-4 Contact Information

National Kaohsiung Center for the Arts (Weiwuying)

No.1, Sanduo 1st Rd., Fengshan Dist., Kaohsiung City 83075, Taiwan

+886 7-262-6666

service@npac-weiwuying.org

0-5 Stage door

Ground floor access is from the north and east side of building. Enter from Operating office entrance on Sanduo 1st Road or Stage Door on Guotai Road.

Basement Level 1 access is from Sanduo 1st Road entrance for Opera House and Playhouse ,Guotai Road entrance for Concert Hall and Recital Hall.

Working pass will be required for entry.

0-6 Auditorium / Seating

Capacities

Area	Capacities
1F	272 seats (include 2 working seats)
2F	906 seats (include 2 working seats)
2F Wheelchairs	9 seats
2F Chorus	185 seats
3F	604 (include 1 working seats)
3F Wheelchairs	5 seats
Total Capacity	1981 seats

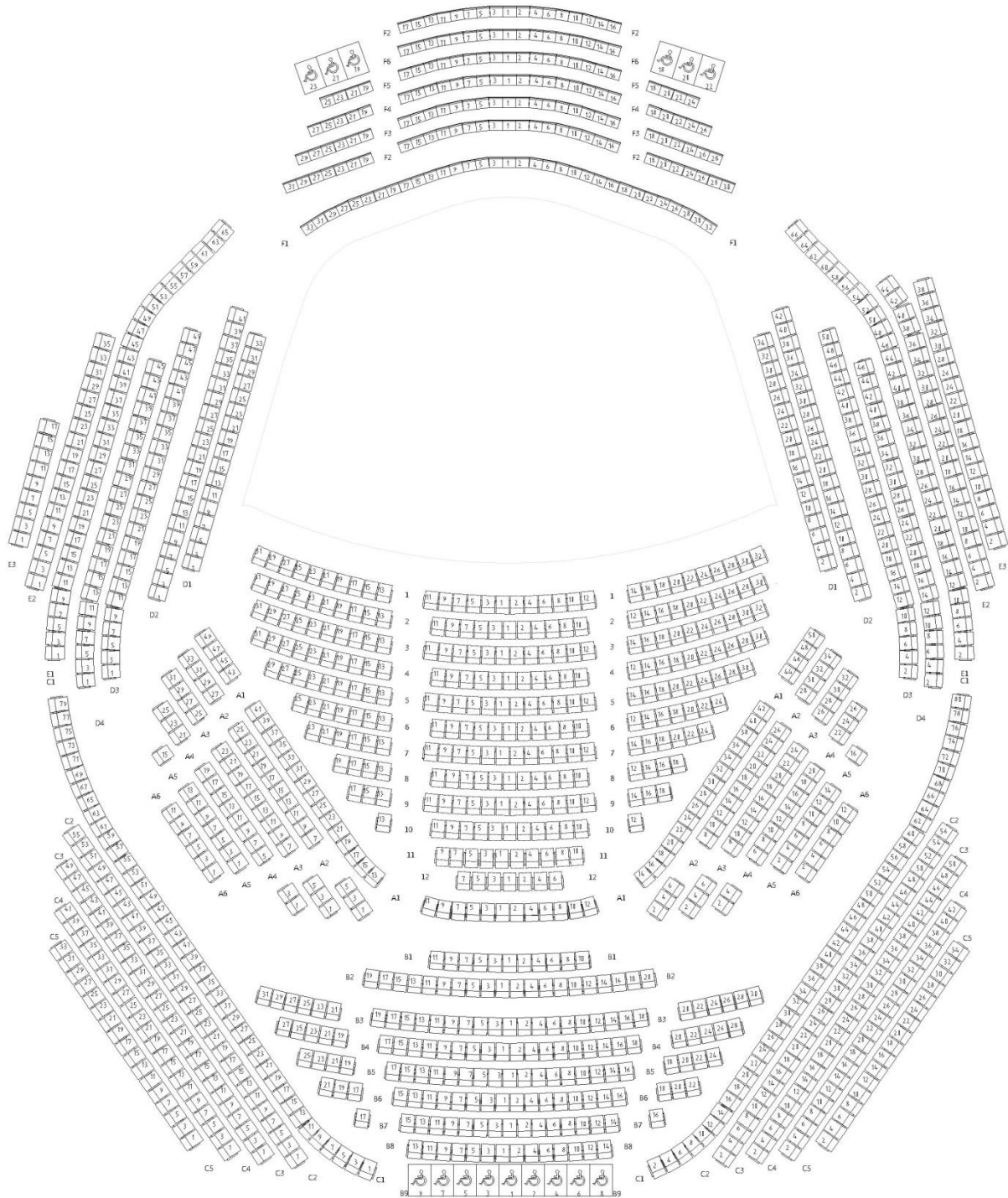

**Concert Hall
Seats Plan /1F & 2F**

Figure 0.1- Concert Hall Seating plan

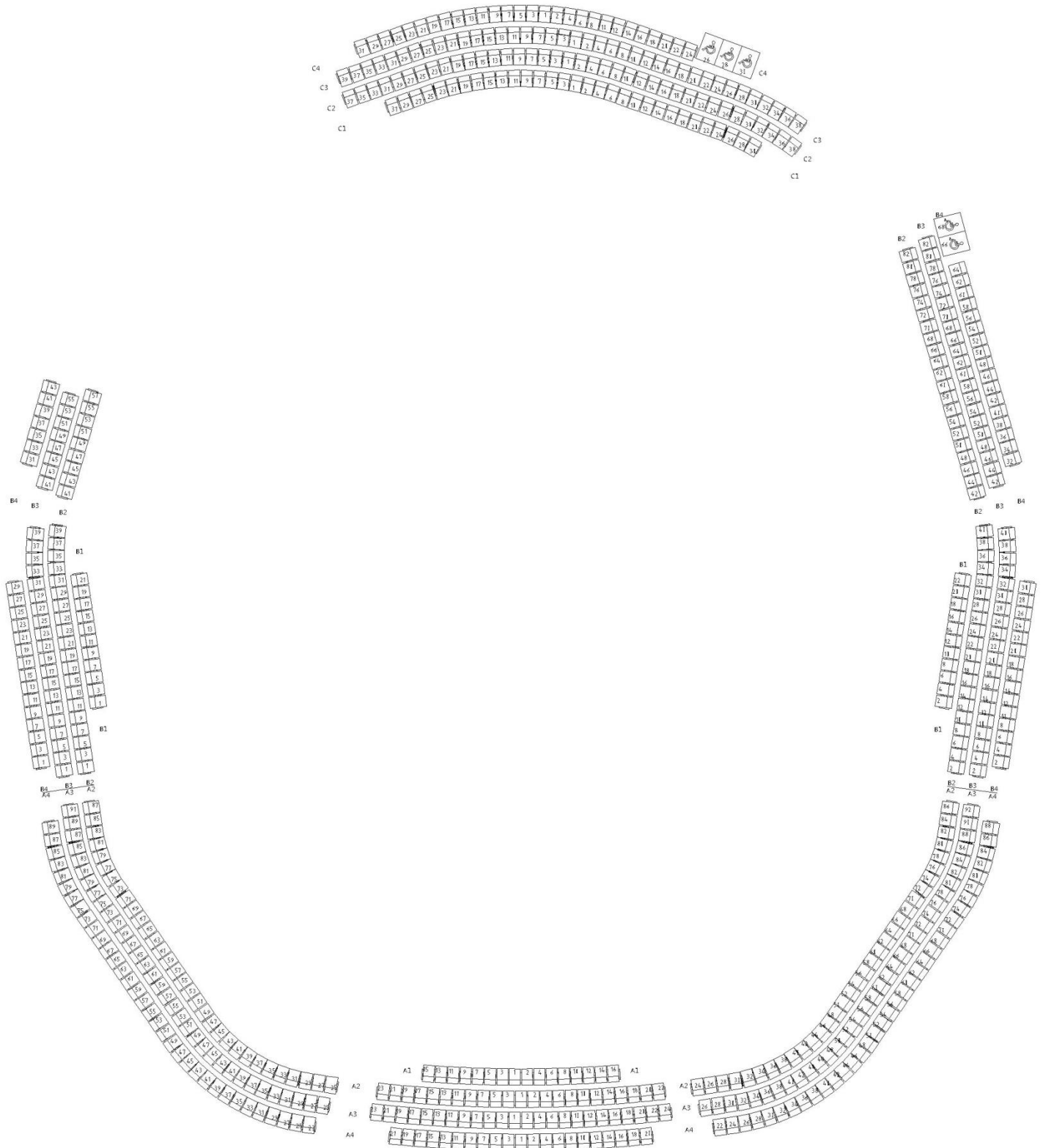

Concert Hall
Seats Plan /3F

Figure 0.2- Concert Hall 3F Seating plan

0-7 Concert Hall Plan

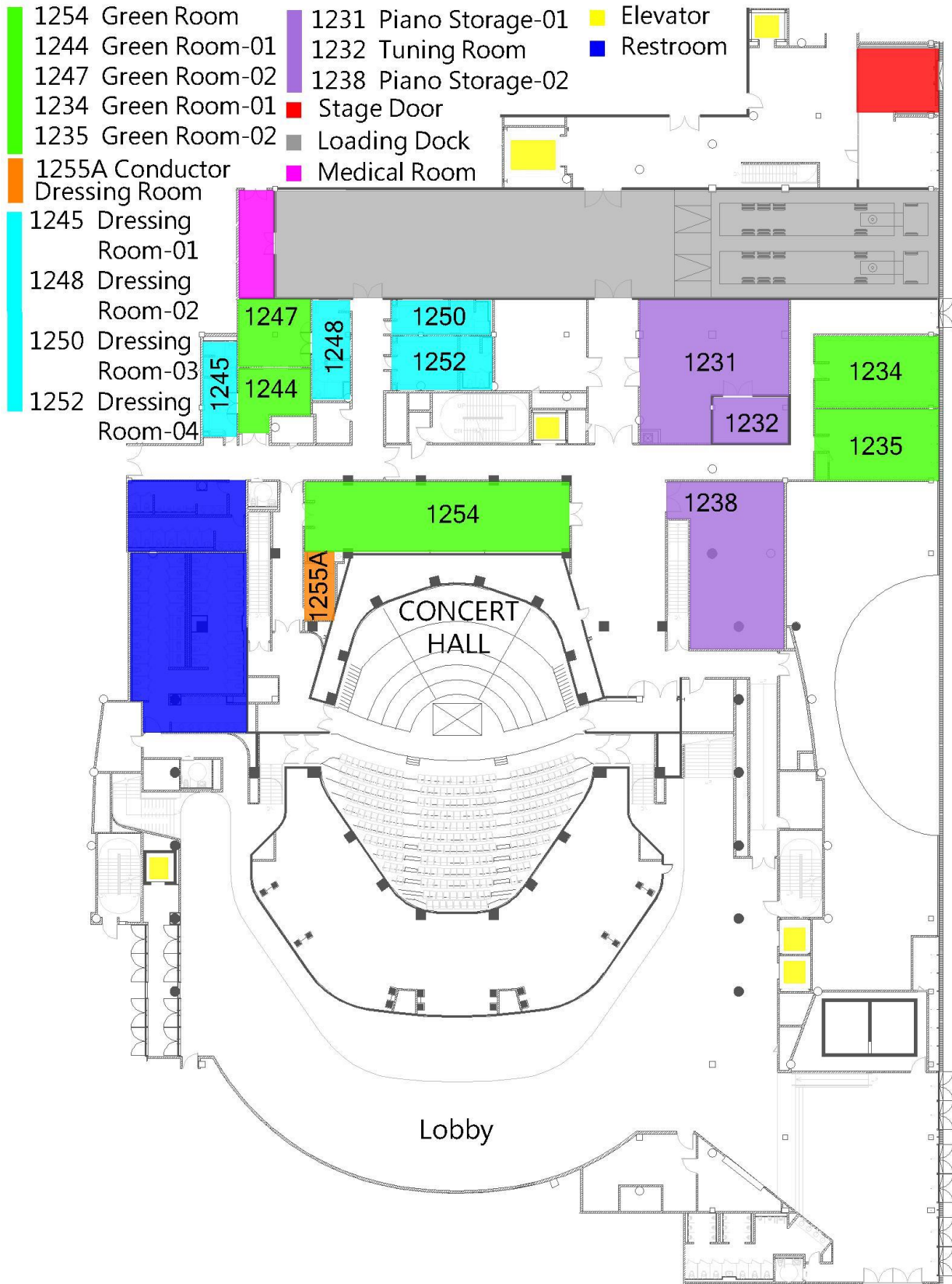

Figure 0.3- Concert Hall 1F plan

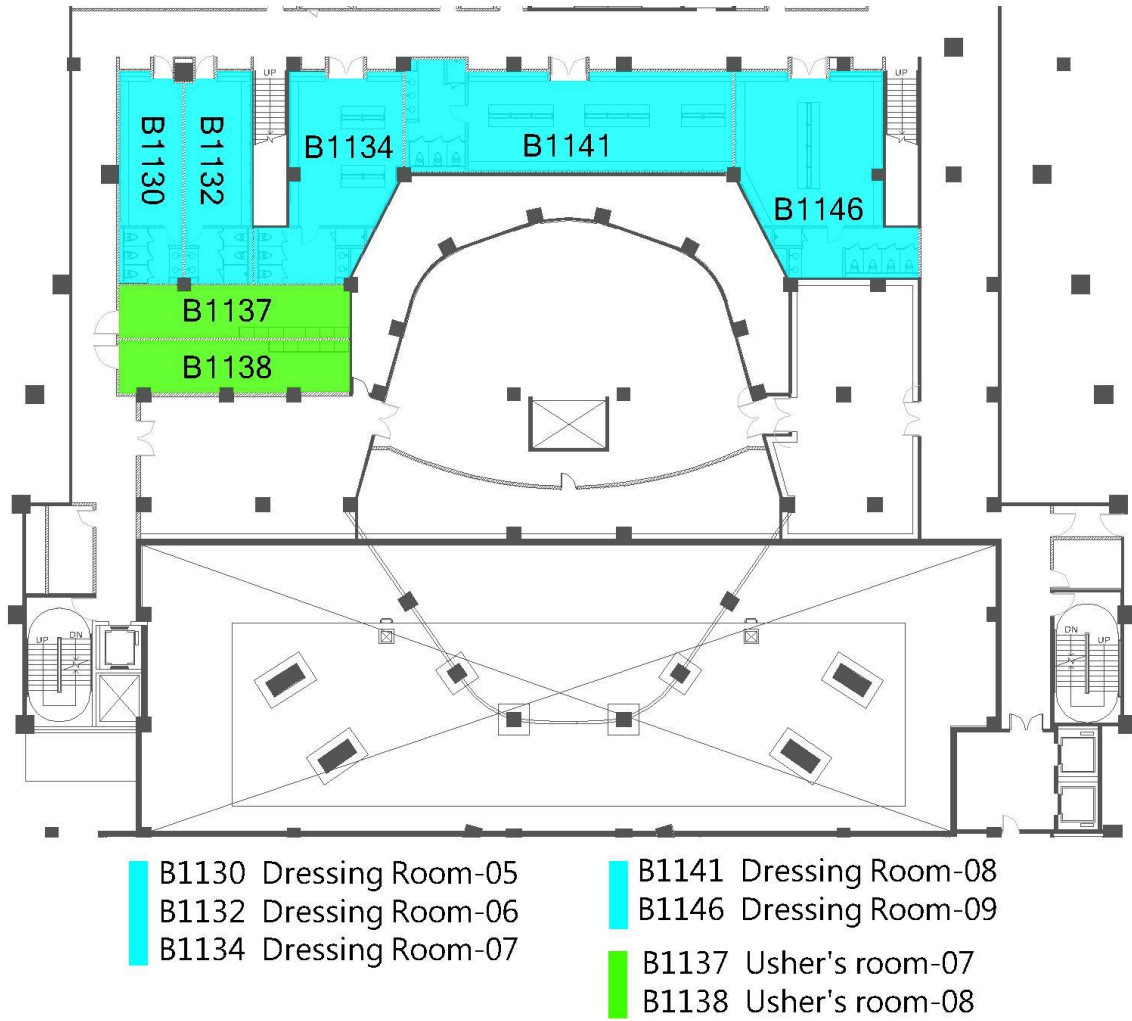

Figure 0.4- Concert Hall B1 plan

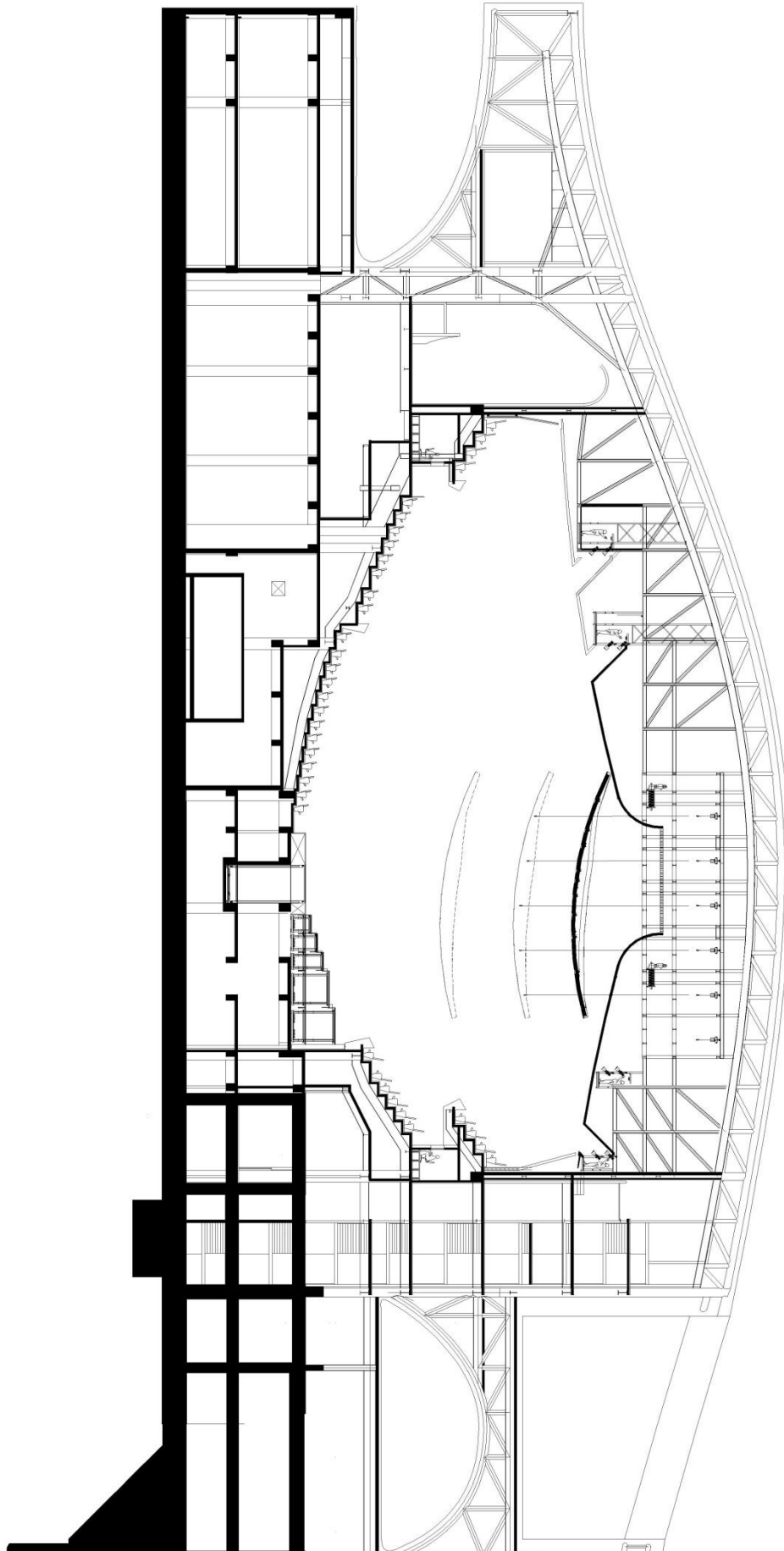

Figure 0.5- Concert Hall Section

1 Stage

1-1 Stage

20.8m (Width) x 13.6m (depth) x 0.8m (height from auditorium floor to stage level)

The stage area is 223.9 m²

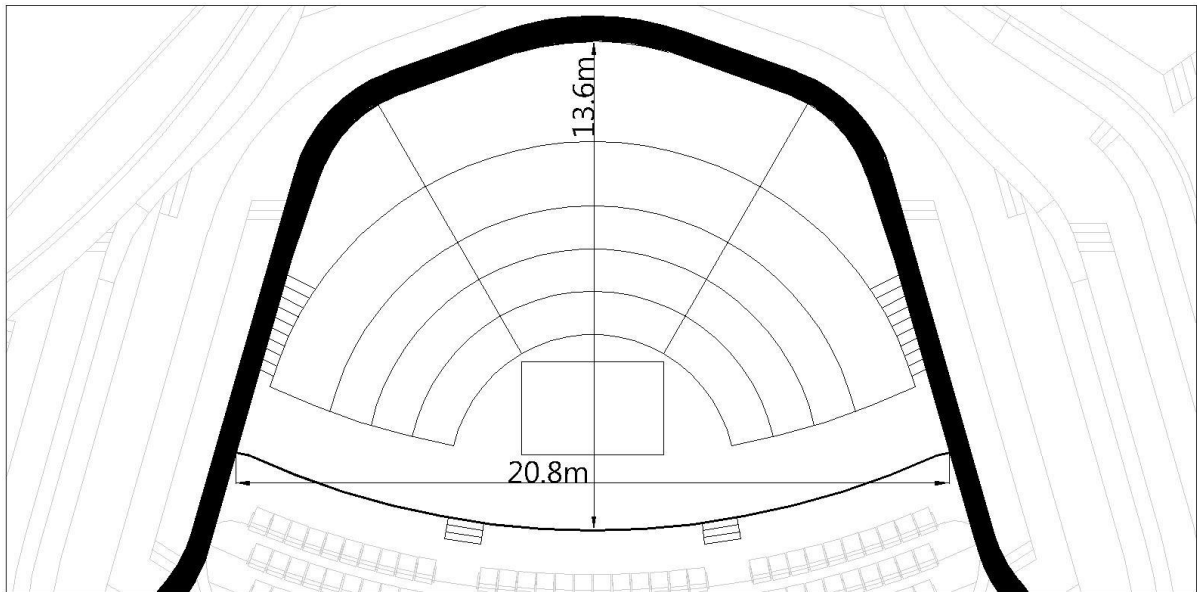

Figure 1.1-Stage Plan

1-2 Hoisting

1-2-1 Chain hoist (load 1000kg, fixed speed: 9.6m/min)

Above Stage, 24 sets, operation length 30m, MoveCat chain hoist

Hoist can be connected to the main controller from both sides of the stage.

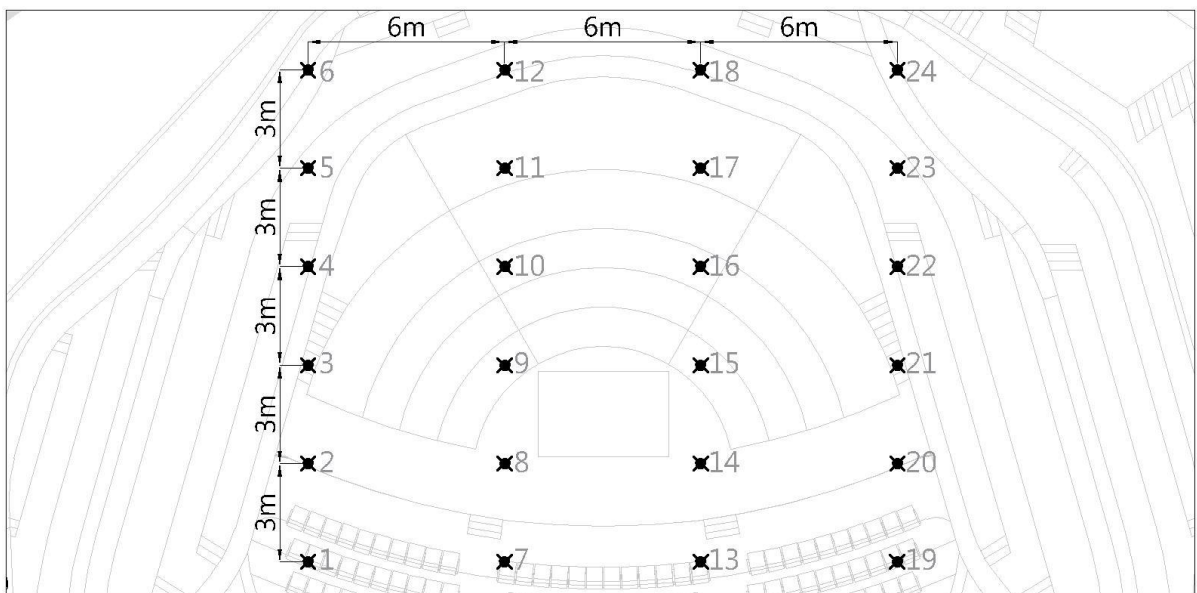

Figure 1.2 - Stage Hoisting plan

1-2-2 Trusses

Aluminum trusses	6 sets	0.3m (side)/4m(length)
	12 sets	0.3m (side)/8m(length)

1-3 Stage Elevation Platform

Stage elevation platform consists of a center stage and five rows of platforms (15 arc platforms). Platforms can be adjusted for different orchestral formations and performance.

The marked lengths and widths below are the maximums, the actual area are shown in square meters.

Position	Platform number	Dimension(Length x Width , Area)	Platform elevation height limit (from stage level)
Row 1	No.1- No.3	1.2m x 4.73m, 5 m ²	40cm
Row 2	No.4- No.6	1.2m x 5.93m, 6 m ²	80cm
Row 3	No.7- No.9	1.2m x 7.13m, 8 m ²	120cm
Row 4	No.10 - No.12	2.4m x 9.53m, 21 m ²	160cm
Row 5	No.13 / No.15	4.65m x 1.0m/2.8m, 9 m ²	200cm
	No.14	2.7m x 9.53m/12.1m, 28.5 m ²	
Center Stage		3.8m x 2.4m, 9.12 m ²	-455cm

Capacity: Static : 500kg/ m²
 Dynamic : 250kg/ m²

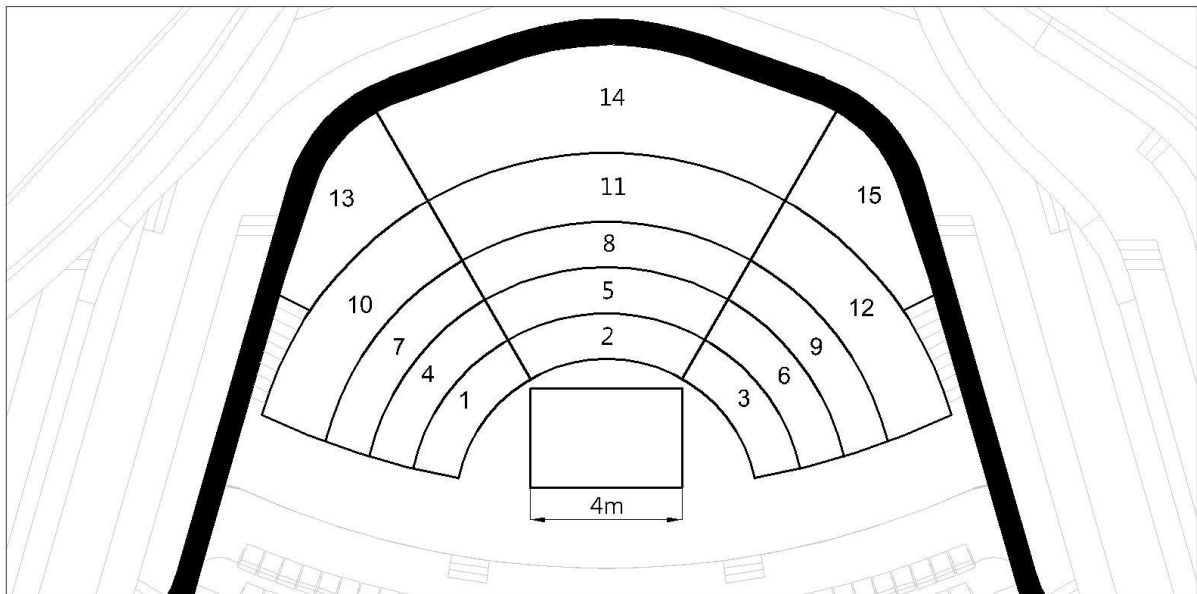

Figure 1.3 – Stage Elevation Platform plan

1-4 Acoustic Panel

The acoustic panel is placed above the stage, with the size of 16m in length, 16.6m in width and the total area of 200 m². Elevation starts from 0.05m to 17.8m. The set heights are 9m, 14m and 17.8m. Equipped with 67 sets of ETC S4 PAR

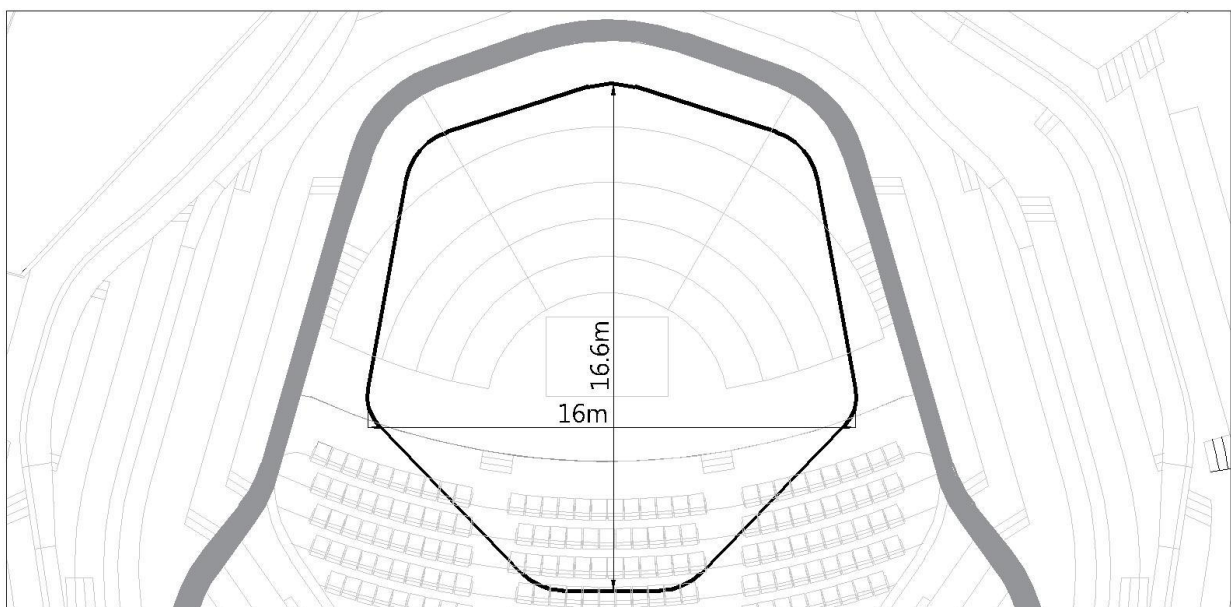

Figure 1.4- Acoustic Panel Plan

2 Lighting

2-1 Lighting System

The basic lighting for stage area is fixedly built in the Acoustic Panel, also provide 9 openable catwalk openings, which can be opened individually by the lighting requirements of the show.

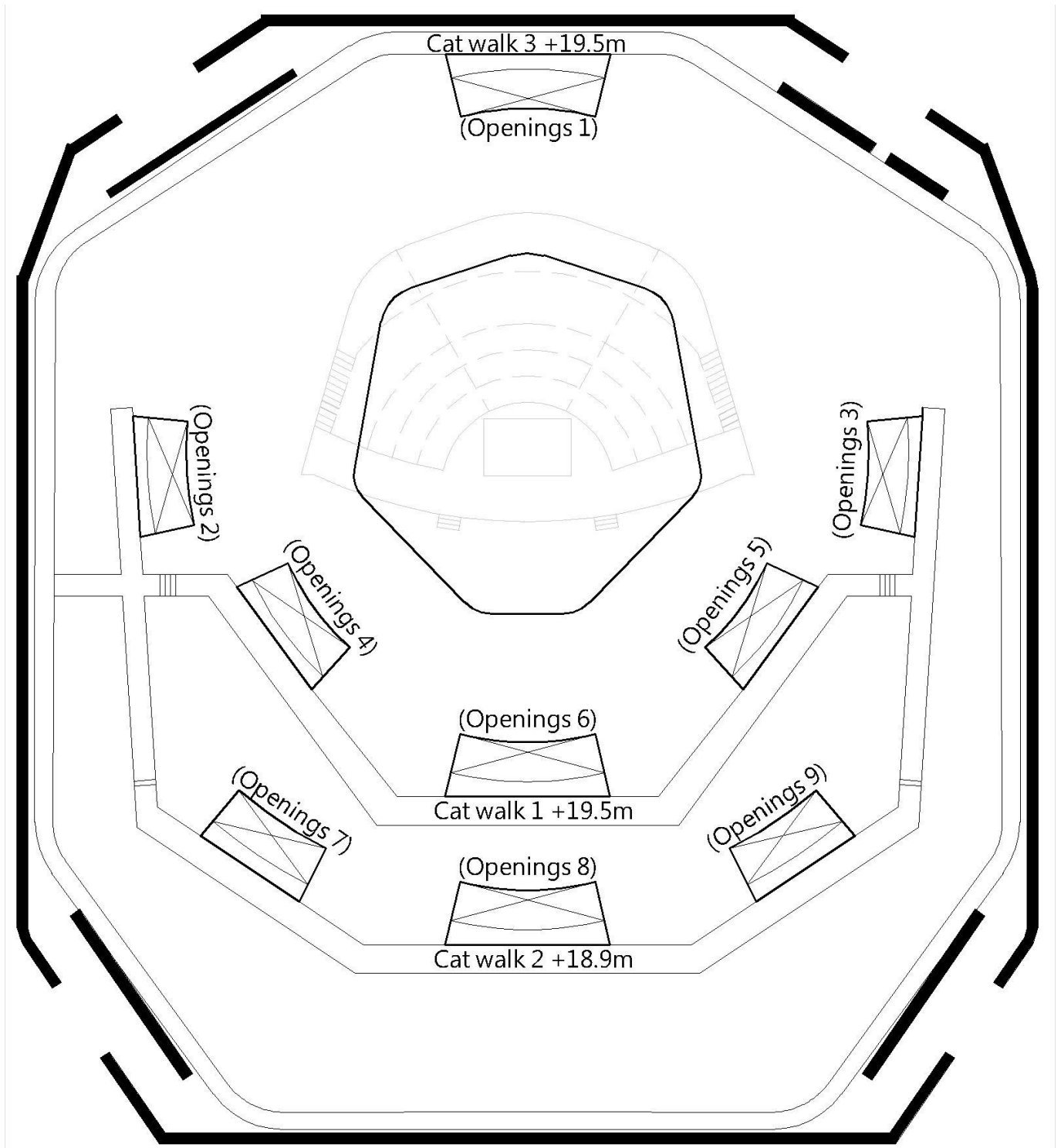

Figure 2.1 - Lighting Openings Position Plan

2-2 Lighting Instrument

Important : control signal were the network system.

Item	Brand and Model No.	Position	Specifications	Quantity	Frame size	Paid Item
Lighting control console	GrandMA 2 Ultra Light	Master Control Booth		1		
		Sub Master Control Booth		1		
Dimmer System	State Automation Solution	Dimmer Room	220V/ 3kW/ CIR	256ch		
Ellipsoidal Reflector Spotlight 10°	Strand Leko Lite 10°	Openings 1	750W	12	305x305mm	
		Openings 2		8		
		Openings 3		8		
		Openings 4		8		
		Openings 5		8		
		Openings 6		10		
		Openings 7		8		
		Openings 8		10		
		Openings 9		8		
Ellipsoidal Reflector Spotlight 15°/35°	Selecon SPX 15°-35°	Openings 2	750W	2	158x158mm	
		Openings 3		2		
		Openings 4		2		
		Openings 5		2		
		Openings 6		2		
		Openings 7		2		
		Openings 8		2		
		Openings 9		2		
Source Four Pars 575W	ETC S4 PAR MCM	Stage Fixed at Acoustic panel	575W	67		
Ellipsoidal Reflector Spotlight 5°	Selecon SPX 5°		750W	10	245x245mm	
Ellipsoidal Reflector Spotlight 19°	Selecon SPX 19°		750W	20	158x158mm	
2KW Fresnel Spotlight 8"	Selecon Arena Theatre 8" Fresnel 7°-60°		2kW	30	245x245mm	
Parabolic Aluminized Reflector Spotlight	Kupo PL-64LB	Lamp : M x 50	1kW	50	254x254mm	
Long Throw Follow Spot	Lycian M2 Model 2060 2.5	Openings 6 Openings 8	2.5kW	2		
Additional Flybar			Bar / Show	1		*
Follow spot operator			Operator / 4 Hour	1		*

*Items with * mark are paid items. Please refer to the rate tables of National Kaohsiung Center for the Arts.*

2-3 Accessories

Item	Specifications	Size	Quantity
Barn door	2kW Fresnel		20
IRIS	For Selecon Ellipsoidal Reflector Spotlight		20
GOBO holder	For Selecon Ellipsoidal Reflector Spotlight	B size	40
Power Distribution Box	8CIR CEE Form Female Plug 		15
Multi-Cable	16pin Multi-Cable	5m	15
		10m	10
		15m	10
Ex-Cable	CEE16A	1.5m	20
		2m	30
		3m	20
		5m	15
		10m	10
		15m	10
Network Cable	RJ45	5m	10
		10m	10

Key	Legend	Quantity	Brand and Model
	Ellipsoidal 15°-30°	16	Philips Selecon SPX 15°-30°
	Ellipsoidal 10°	80	STRAND LEKO LITE 10°
	2.5kw Long Throw Followspot	2	Lycian M2 Model 2060 2.5

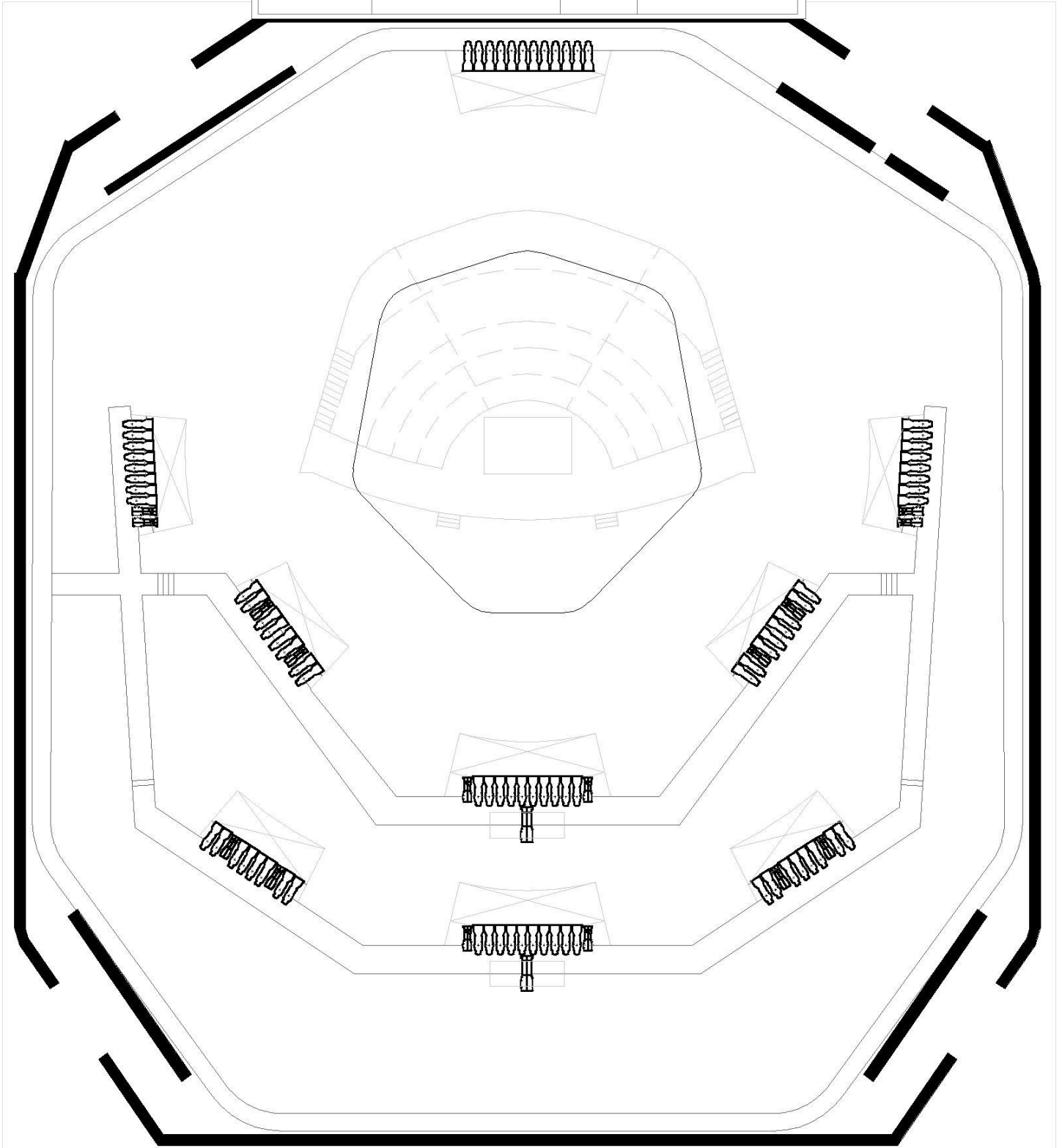

Figure 2.2- FOH Lighting Plan

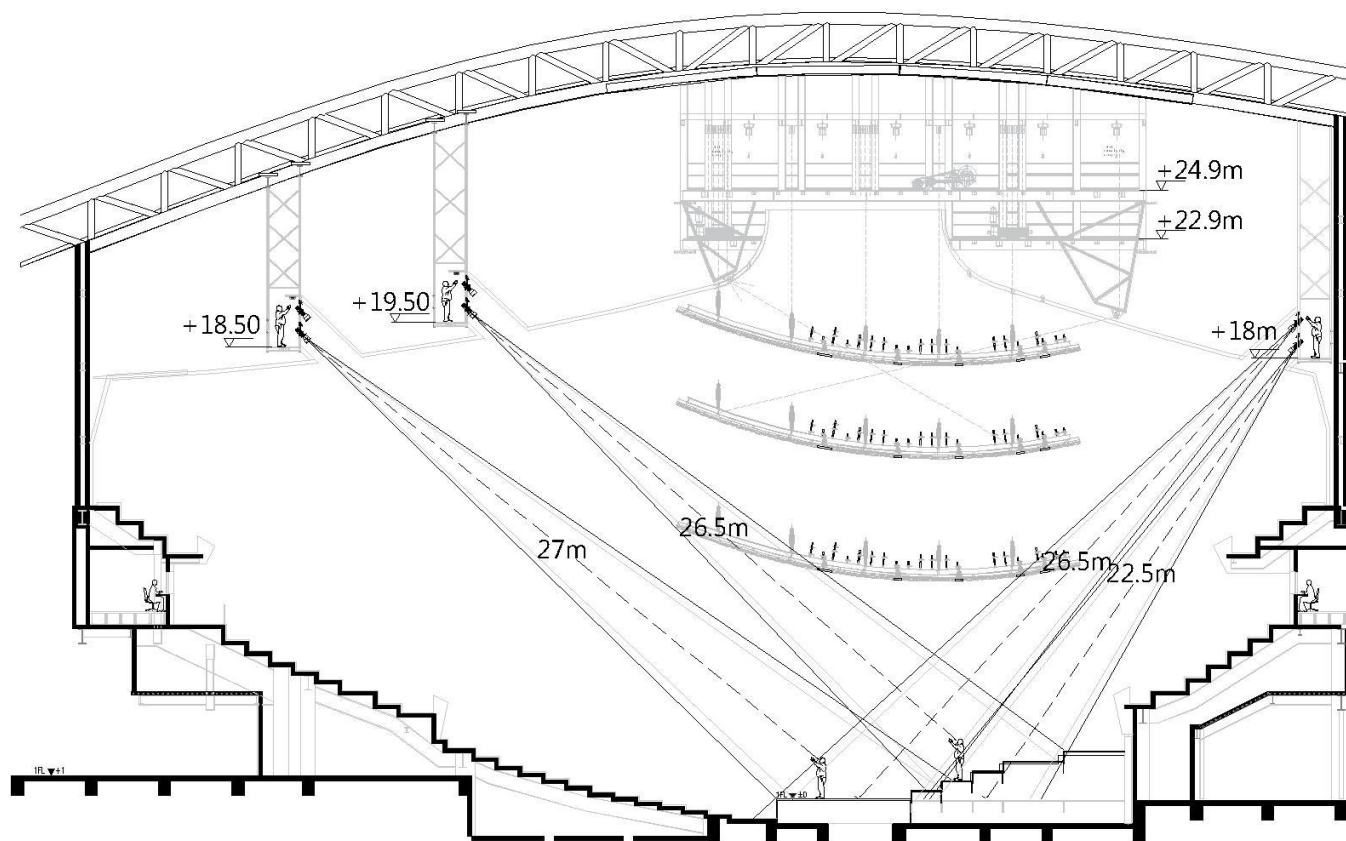

Figure 2.3- Lighting Section

2-3 Lighting Circuit

2-3-1 Stage area

Area and Position	Dimmer Circuit No.	Load	Network Circuit No.
Down Stage/L	001 ~ 008	3kw	LN01~LN02
	009 ~ 016		
Down Stage/R	017 ~ 024	3kw	LN03~LN04
	025 ~ 032		
Stage Right Waiting Area			LN05~LN08
Under Auditorium 12 rows			LN09~LN16

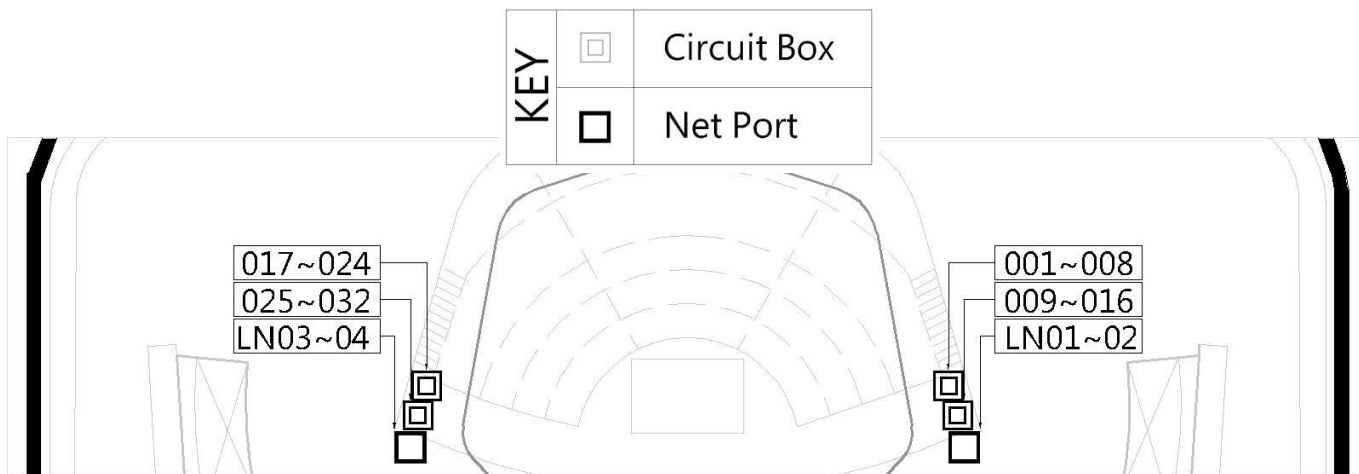

Figure 2.4.1- Stage Area Lighting Circuit Layout

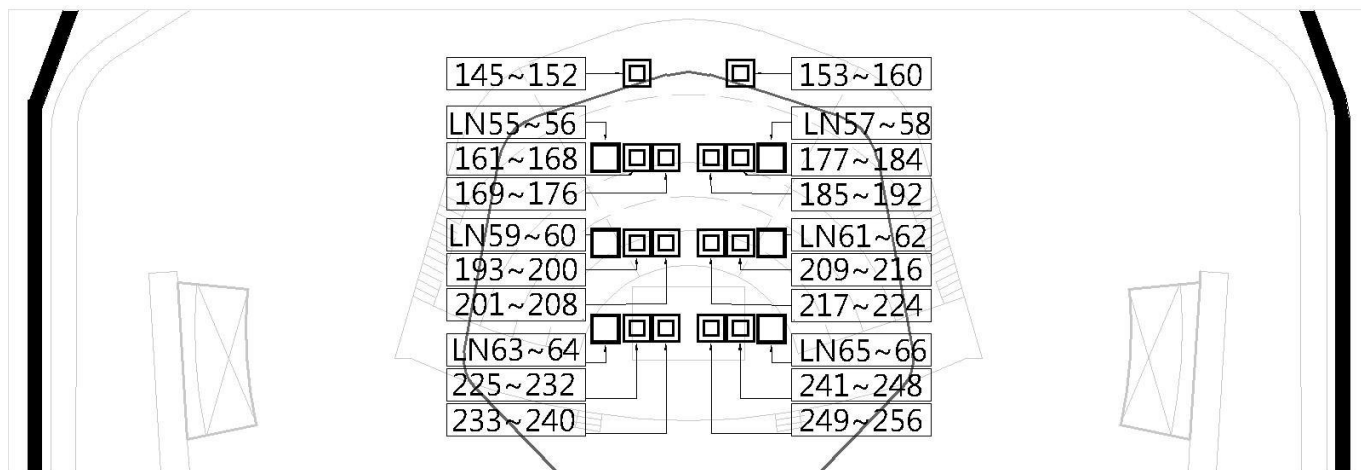

Figure 2.4.2 Grid Area Lighting Circuit Layout

2-3-2 Front of House

Area and Position		Dimmer Circuit No.	Load	Network Circuit No.
Master Control Booth				LN17~LN24
Sub Master Control Booth				LN25~LN32
Openings 1	3 rd. Catwalk -Rear Stage	129 ~ 132	3kw	LN53~LN54
		133 ~ 136		
		137 ~ 140		
		141 ~ 144		
Openings 2	Lighting Box/R	045 ~ 048	3kw	LN39~LN40
		049 ~ 052		
		053 ~ 056		
Openings 3	Lighting Box/L	033 ~ 036	3kw	LN37~LN38
		037 ~ 040		
		041 ~ 044		
Openings 4	1st. Catwalk-Stage/R	081 ~ 084	3kw	LN45~LN46
		085 ~ 088		
		089 ~ 092		
Openings 5	1st. Catwalk-Stage/L	057 ~ 060	3kw	LN41~LN42
		061 ~ 064		
		065 ~ 068		
Openings 6	1st. Catwalk -Center	069 ~ 072	3kw	LN43~LN44
		073 ~ 076		
		077 ~ 080		
Openings 7	2nd. Catwalk- Stage/R	105 ~ 108	3kw	LN49~LN50
		109 ~ 112		
		113 ~ 116		
Openings 8	2nd. Catwalk -Center	117 ~ 120	3kw	LN51~LN52
		121 ~ 124		
		125 ~ 128		
Openings 9	2nd. Catwalk - Stage/L	093 ~ 096	3kw	LN47~LN48
		097 ~ 100		
		101 ~ 104		
Acoustic panel	Grid-Up Stage	145 ~ 152	3kw	
		153 ~ 160		
Stage Grid area	Grid-Up S.R.	161 ~ 168	3kw	LN55~LN56
		169 ~ 176		
	Grid-Up S.L.	177 ~ 184	3kw	LN57~LN58
		185 ~ 192		
	Grid-Center S.R.	193 ~ 200	3kw	LN59~LN60
		201 ~ 208		
	Grid- Center S.L.	209 ~ 216	3kw	LN61~LN62
		217 ~ 224		
	Grid-Down S.R.	225 ~ 232	3kw	LN63~LN64
		233 ~ 240		
	Grid- Down S.L.	241 ~ 248	3kw	LN65~LN66
		249 ~ 256		

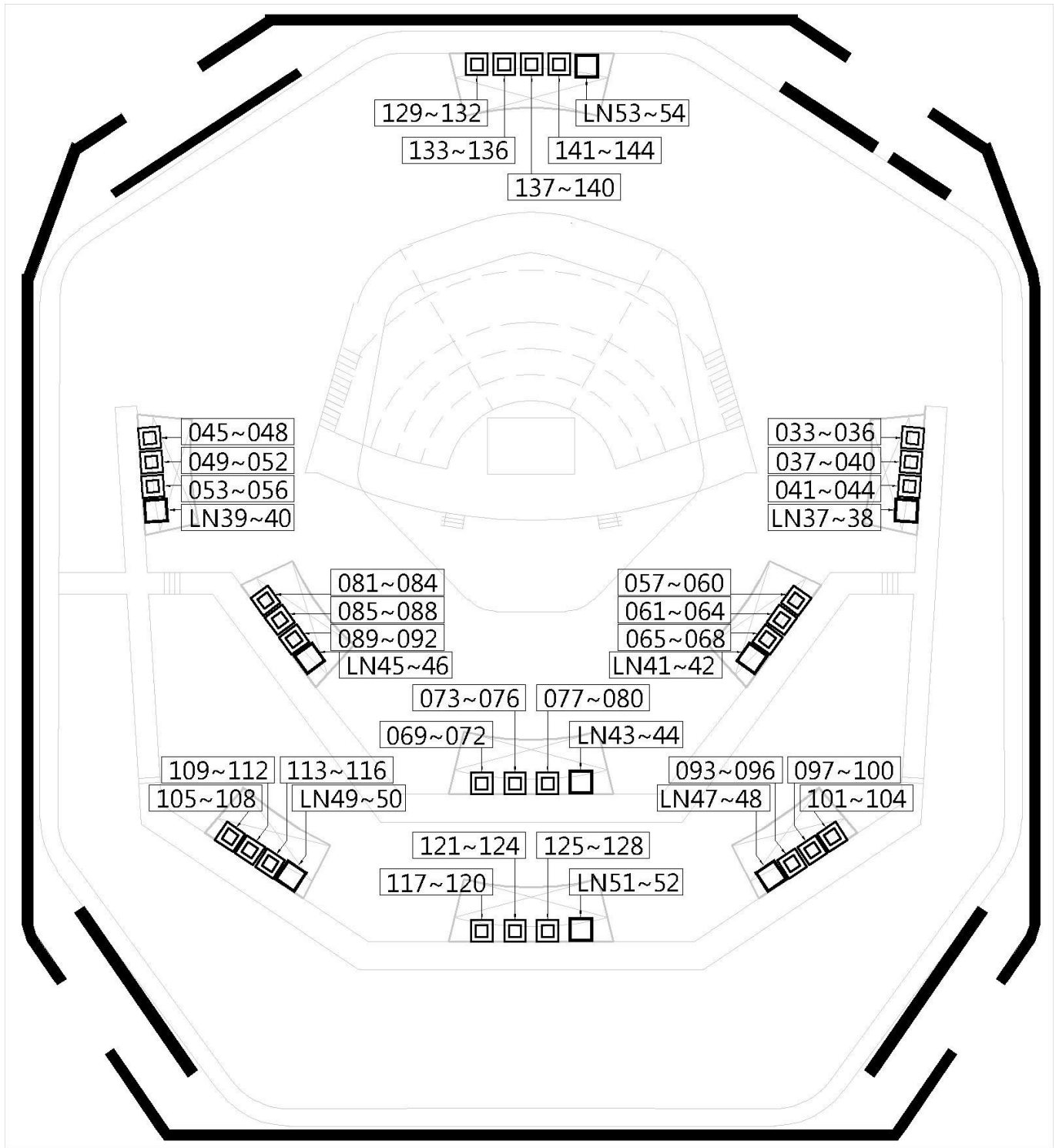

Figure 2.4.3- FOH Lighting Circuit Layout

2-4 Portable Lift

Brand and Model : Snorkel UL-40 (rechargeable)
 Maximum height: 12.1m
 Maximum weight: 136kg
 Quantity: 1

2-5 Additional Power Supply

Function	Position	Specifications	Quantity
Stage	Stage Left / Right	3φ4W+G 380V/220V/60Hz (CEE 125A/3P+N+E)	1 / 1
Light		3φ4W+G 220V/120V/60Hz (Camlock 250A)	1 / 1
Sound		3φ4W+G 220V/120V/60Hz (Camlock 50A)	1 / 1

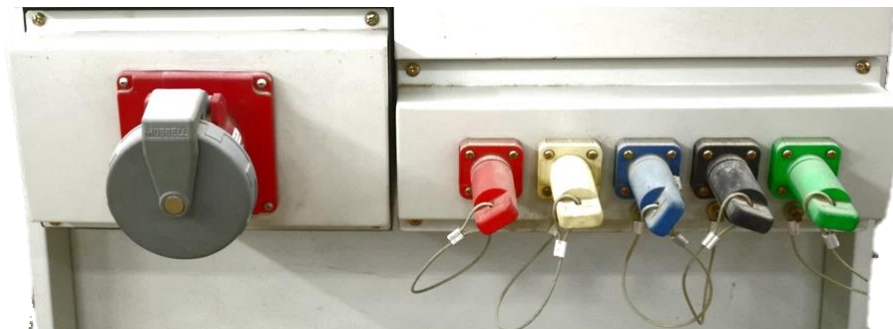

Figure 2.5 - Additional Power Supply

2-6 House Light / Working Light / Blackout

Work lights

Work lights provided white and blue light mode, and the control switch is located on the stage manager' s Desk.
 Lighting area: Side stage entrance, Stage machine pit, Grid area and Cat walk.

Auditorium lights

Auditorium lights consists houselights and step lights, which can be separately controlled and dimmed. The control panel is located on the stage manager' s Desk and lighting control room.

Blackout

In accordance with government Fire Services Act, there are many of emergency lights in the venue. We cannot extinguish the emergency lighting for any performance, there will be the minimal lighting levels in the auditorium and backstage areas.

3 Audio/Video Systems

3-1 Audio Facilities

Item	Quantity	Brand and Model	Paid Item
Digital mixer	1	Studer Vista 5 M3/32	
Digital speaker	2	Renkus-Heinz ICONYX IC24RII	
Digital speaker	2	Renkus-Heinz ICONYX IC16RII	
Digital speaker	8	Renkus-Heinz ICONYX IC8RII	
Stage front speaker	7	Renkus-Heinz CFX41	
12" Stage Active speaker	8	Renkus-Heinz PN121M/12	*
6.5" Stage Active speaker	8	Renkus-Heinz PN61	*
Digital I/O Fiber Module	2	Studer D21M	
Dual channel Equalizer	4	BSS FCS 960	*

*Items with * mark are paid items. Please refer to the rate tables of National Kaohsiung Center for the Arts.*

3-2 Control Room

Item	Quantity	Brand and Model	Paid Item
Main Digital mixer	1	Studer Vista 5 M3/42	
Digital I/O Fiber Module	1	Studer D21M	
CD PLAYER	1	Tascam CD-500B	*
CD-R PLAYER	1	Tascam CD-RW 901 MKII	*
Multitrack Recording equipment	1	Joeco BBR1D+2.5" USB 1TB HD	*
Dual track Hard disk recorder	1	Tascam DA 3000	*
Active speakers	4	Dynaudio BM12 MkIII	

*Items with * mark are paid items. Please refer to the rate tables of National Kaohsiung Center for the Arts.*

3-3 Stage Manager' s Console

The stage manager' s console is equipped with a near-field monitor speaker, stage video monitors ,synchronous show screens with lighting and flying system controller ,communication system and live announcements to individual space in backstage.

3-4 Machine Room

Item	Quantity	Brand and Model	Note
Digital Audio Management	1	Studer D21M (Studer Score Live)	
Digital I/O Fiber Module	1	Studer D21M	

3-5 Microphone

Item	Quantity	Brand and Model	Paid Item
Dynamic microphone	2	Audio Technica AE4100	*
Dynamic microphone	6	Audio Technica ATM250	*
Condenser microphone	2	Audio Technica AE5400	*
Cardioid Condenser microphone	6	Audio Technica AT4021	*
Cardioid Condenser Boundary Microphone	4	Audio Technica U851R	*
Stage reception Microphone	2	DPA 4017B / DPA UA0836 Holders	
Hypercardioid Condenser microphone	8	AKG CK63-ULS+ C480B	*
Cardioid condenser microphone	8	AKG CK61-ULS + C480B	*
wireless microphone	4	Sennheiser SKM500G3+MME865	*
Mini wireless microphone	8	Sennheiser SK500G3+MKE2	*
Single channel wireless microphone receiver	12	Sennheiser EW500G3	
Wireless microphone wave antenna	2	Sennheiser AD3700	
Wave antenna distributor	3	Sennheiser ASA1	
Microphone Stand Cross bar	12	K&M 210/6	
Microphone Stand Telescopic bar	12	K&M 210/8	
Microphone dwarf with telescopic crossbar	4	K&M 259	

Items with * mark are paid items. Please refer to the rate tables of National Kaohsiung Center for the Arts.

3-6 Communications

Item	Quantity	Brand and Model	Paid Item
Intercom host machine	1	Clear-Com Eclipse HX-Delta	
Phone interface	1	Clear-Com TEL-14	
System interface	1	Clear-Com Helixnet HMS-4X	
Double circuit intercom	7	Clear-Com Helixnet HBP-2X	
Fixed intercom microphone/ speak	1	Clear-Com V12PDXY 110 / 340 Clear-Com V12PDDXY 110 / 340	
Single head receiver microphone	4	Clear-Com CC-300	
Double head receiver microphone	3	Clear-Com CC-400	
Telephone intercom	4	Clear-Com HS-6	
Digital Wireless Intercom set	4	1. Portable wireless sub-station / Clear-Com FS-BP 2. Single-ear headset / Clear-Com CC-300	*

Items with * mark are paid items. Please refer to the rate tables of National Kaohsiung Center for the Arts.

3-7 Locations of Communications

Each floor is paired with intercom system, 27units in total.

Item Number	Floor	Location
1	B1F	Storage room
2	1F	Stage left preparation area
3		Stage right preparation area
4		Stage left
5		Stage right
6		Auditorium seating area 12 row
7		Loading Dock
8		Sound room
9		Recording studio
10		Green room 1
11		Dressing room 2
12		Dressing room 3
13		Dressing room 4
14		2MF
15	Master control room	
16	Deputy Control Room	
17	4F	Dimmer room
18		Amplifier room
19	R1F	Catwalk 1 st (Lightingopen4)
20		Catwalk 1 st (Lightingopen5)
21		Catwalk 1 st (Lightingopen6)
22		Catwalk 1 st (Lightingopen7)
23		Catwalk 2 st (Lightingopen8)
24		Catwalk 2 st (Lightingopen9)
25		Stageright Box(Lightingopen3)
26		Stageleft Box(Lightingopen2)
27		Catwalk(Lightingopen1)

3-8 Stage Cameras and Video Surveillance Systems

Stage monitors are installed in right and left stage entrances, first, second, and third floor lobbies, master and secondary control rooms, dressing rooms and green rooms.

Item	Quantity	Brand and Model	Paid Item
Camera (2/3 inch 3CCD)	2	Panasonic AW-HE870 Panasonic LZ20M85G	
Remote control	1	Panasonic AW-RP50	
Switcher	1	Panasonic AW-RP120	
Mixer circuit	Circuit / Show		*
Video recording	Show	Fixed camera for stage panoramic view recording, only suitable for archived copy.	
Sound recording	Show	Live sound recording, only suitable for archived copy.	

Items with * mark are paid items. Please refer to the rate tables of National Kaohsiung Center for the Arts.

3-9 Paging Systems

Backstage Paging Systems

There are four venues individually Backstage Paging Systems in National Kaohsiung Center for the Arts. For Concert Hall paging available to all dressing rooms, green rooms, office and passage,it can also available paging to separately 5 zones. The Paging and Program position is located on the stage manager' s console.

Zone 1 : 1234 Green Room-01 、 1235 Green Room-02 、 B1137 Usher's room-07 、 B1138 Usher's room-08

Zone 2 : 1254 Green Room 、 B1130 Dressing Room-05 、 B1132 Dressing Room-06 、 B1134 Dressing Room-07 、 B1141 Dressing Room-08 、 B1146 Dressing Room-09

Zone 3 : Passage B1126

Zone 4 : Passage (1230 、 1240 、 1233 、 1255 、 1256 、 1257)

Zone 5 : 1244 Green Room-01 、 1245 Dressing Room-01 、 1247 Green Room-02 、 1248 Dressing Room-02 、 1250 Dressing Room-03 、 1252 Dressing Room-04 、 1255A Conductor Dressing Room

4 Backstage

4-1 Dressing Room and Green Room

No.	Floor	Room No.	Name	Capacity	Notes
1	1	1234	Green room 01	20	Includes table and chairs.
2		1235	Green room 02	20	Includes table and chairs.
3		1244	Green room 01	3	Includes dressing mirror, table and chairs.
4		1245	Dressing room 01	3	Includes mirror, table and chairs, toilet and shower
5		1247	Green room 02	3	Includes upright piano, dressing mirror, table and chairs.
6		1248	Dressing room 02	2	Includes mirror, table and chairs, toilet and shower
7		1250	Dressing room 03	3	Includes mirror, table and chairs, toilet and shower
8		1252	Dressing room 04	5	Includes mirror, table and chairs, toilet and shower
9		1254	Green room	30	Includes dressing mirror, table and chairs.
10	B1	B1130	Dressing room 05	7	Includes mirror, table and chairs and toilet
11		B1132	Dressing room 06	7	Includes mirror, table and chairs, toilet and shower
12		B1134	Dressing room 07	13	Includes mirror, table and chairs, toilet and shower
13		B1141	Dressing room 08	29	Includes mirror, table and chairs, toilet and shower
14		B1146	Dressing room 09	20	Includes mirror, table and chairs, toilet and shower

4-2 Orchestra Facilities

No.	Item	Quantity	Notes
1	Chair	100	
2	Ensemble stool	10	
3	Conductor' s chair	1	
4	Music stand	100	
5	Music stand light	100	White light, two brightness mode
6	Conductor' s podium	1	WENGER Base podium:1.09 x 0.97 x 0.15 m Upper podium:0.81 x 0.97 x 0.15 m
7	Conductor' s stand	1	WENGER Desk is 0.69(w)x0.51(d)m Desk height is adjustable from 0.76-1.2m
8	Percussion table stand	3	
9	Endpin stopper	10	
10	Acoustic shield	4	

4-3 Pianos (shared between four venues)

No.	Item	Brand	Model Number	Quantity	Notes
1	Model-D Concert grand	Steinway & Sons	D-274	3	*
2	Concert grand	FAZIOLI	F308	1	*
3	Grand Piano	YAMAHA	C7XPE	1	*
4	Grand Piano	KAWAI	SK-6L	1	*
5	Celesta	Schiendmayer	5 ½ Octave Studio model	1	*
6	Harpichord	J.C.NEUPERT	Hemsch	1	*

*Items with * mark are paid items. Please refer to the rate tables of National Kaohsiung Center for the Arts.*

Important : *Pianos shared with four venues ,booking in advance is required.*

WEIWUYING's contract-signed piano technician must tune all pianos before performance.(Piano hire fees do not include tuning costs)

4-4 Loading Dock/ Scenery Shipping Path / Loading Flow

4-4-1 East Dock

Recital Hall and Concert Hall use the East Dock for loading and unloading. The dock is equipped with two hydraulic dock leveler that can be adjusted according to the required height.

Dock Dimension

Dimension: 8.75m (width)

Clearance: 4.38m (height from floor to top)

3.8m (height from dock to grid area)

Stage entrance: minimum 1.95m (width) x 2.2m (height)

Height from dock to floor: 0.98m

4-4-2 Handling equipment

Platform Trolley (with handle)x10 (0.9m x1.8m)

1.5mt Stand-Up Automatic Electric Forklift x1

3mt Manual Hydraulic Pallet Jack x1

West Dock Handling equipment

The West Dock equipment is mainly used by Opera House and Playhouse. In need, please requests in advance.

Platform Trolley x20 (1.2m x2.4m)

2.5mt Electric Forklift x1

1.5mt Stand-Up Automatic Electric Forklift x1

3mt Manual Hydraulic Pallet Jack x2

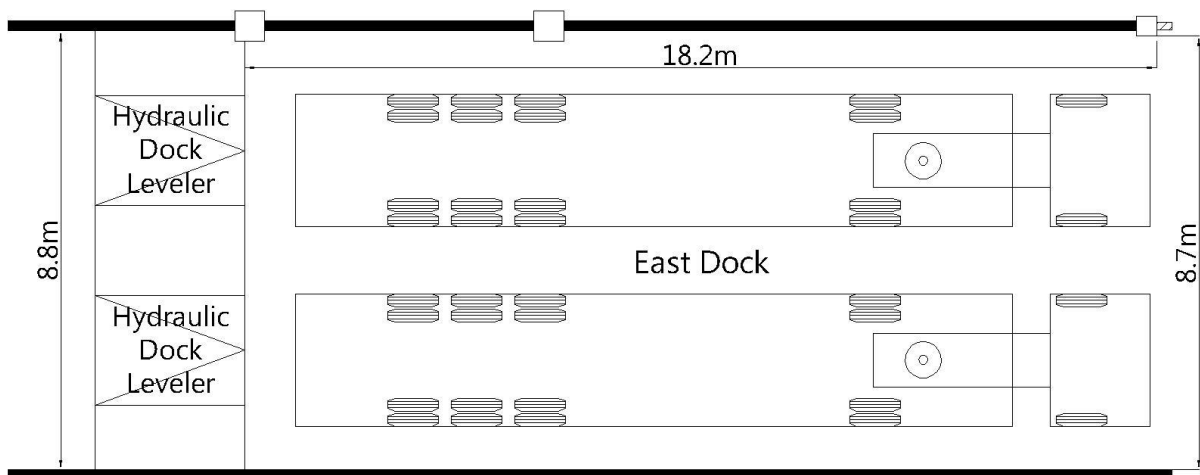

Figure 4.1- East Loading Dock Plan

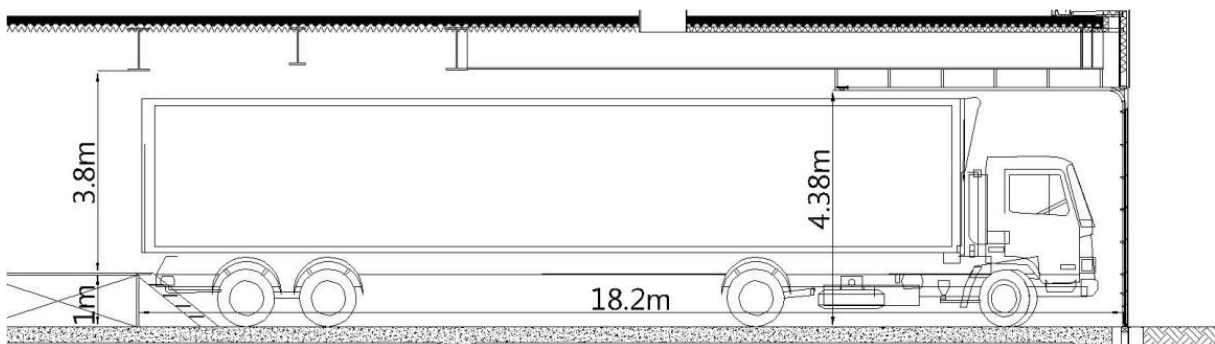

Figure 4.2- East Loading Dock Section

4-4-3 Loading Flow

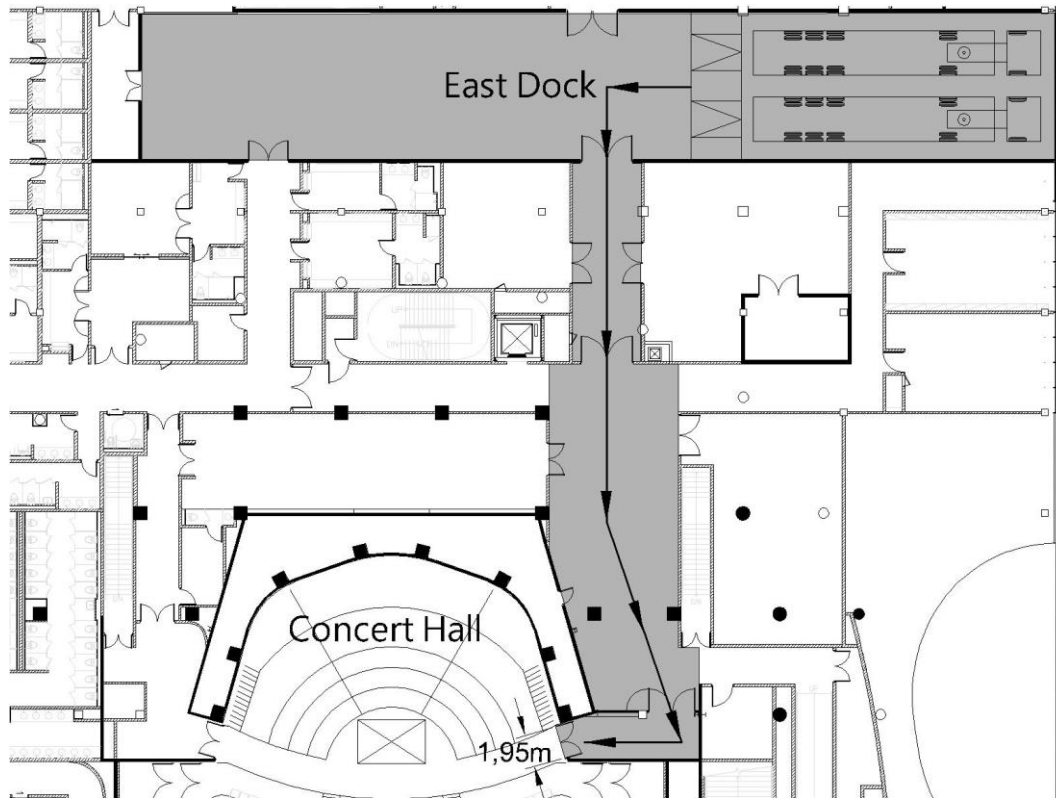

Figure 4.3 - Loading Flow

4-4-4 Hydraulic Dock Leveler

Capacity: 22.6mt

Area: 198cm (width) x 221.9cm (length)

Elevation: +/- 30.5cm

Quantity: 2 on east dock

4-5 Other Facilities

4-5-1 Rehearsal Rooms

There is no rehearsal studio dedicated to the Concert Hall. Additional rehearsal space is limited across the WEIWUYING. There are 13 different function and accommodated rehearsal studios, these available for hire between four major theatres .Requests should be discussed well in advance to determine availability. The hire fees please refer to the rate tables of National Kaohsiung Center for the Arts.

Room No.	Name	Dimension (Length x Width x Height / m)	Notes
B313	Orchestra Studio	23.2×18.1×7.8	1. fixed auditorium < 84seats> 2. Grand Piano ,Chair , Ensemble stool 3. Wooden floor 4. Sound absorption curtain
B304	Chorus Rehearsal Room	17×11.2×8.8	1. Grand Piano ,Chair , Ensemble stool 2. Wooden floor 3. Sound absorption curtain
1171	Rehearsal Studio-01	13.1×21.5×11.7	1. Grand Piano 2. Wooden floor covered black color dance floor 3. Wall mount glassless mirrors x 1 side Opera House rehearsal room
1182	Rehearsal Studio-02	12.8×22.3×4	1. Wooden floor covered gray color dance floor 2. Sound absorption wall x 2 side 3. Wall mount glassless mirrors x 2 side
1184	Rehearsal Studio-03	12.8×22.3×4	1. Grand Piano 2. Wooden floor covered gray color dance floor 3. Sound absorption wall x 2 side 4. Wall mount glassless mirrors x 2 side
1186	Rehearsal Studio-04	12.8×22.3×4	1. Grand Piano 2. Wooden floor ,black color dance floor 3. Wall mount glassless mirrors x 2 side 4. Fixed Ballet barre on the single sided wall mirror x 2
		6.6×8.8 ×3	Rehearsal Studio-04 use only Green Room-01(With dressing room)
1192	Rehearsal Studio-05	12.8×22×4	1. Grand Piano 2. Wooden floor , black color dance floor 3. Wall mount glassless mirrors x 2 side 4. Fixed Ballet barre on the single sided wall mirror x 2
		6.6×8.8 ×3	Rehearsal Studio-05 use only Green Room-02(With dressing room)
B1111	Rehearsal Studio-06	8.5×9×2.7	1. Upright piano ,Chair , Music stand 2. Wooden floor 3. Sound absorption wall
B1112	Rehearsal Studio-07	6.3×5.2×2.7	1 Chair , Music stand 2. Wooden floor 3. Sound absorption wall
B1113	Rehearsal Studio-08	5.7×8.4×3.3	1. Chair , Music stand 2. Wooden floor 3. Sound absorption wall
B1114	Rehearsal Studio-09	5.7×5.6×3.3	1. Chair , Music stand 2. Wooden floor 3. Sound absorption wall
B1115	Rehearsal Studio-10	5.7×5.6×3.3	1. Chair , Music stand 2. Wooden floor 3. Sound absorption wall
B1116	Rehearsal Studio-11	5.7×5.6×3.3	1. Chair , Music stand 2. Wooden floor 3. Sound absorption wall

4-5-2 Carpentry Shop / Metal Shop / Costume Shop / Laundry Room

National Kaohsiung Center for the Arts is equipped with basic production facilities, include Carpentry Shop, Metal Shop, Costume Shop, and laundry rooms. Those for hire between four major theatres .The hire fees please refer to the rate tables of National Kaohsiung Center for the Arts.

Room No.	Name	Dimension (Length x Width x Height / m)	Notes
1002	Carpentry Shop	11.9×19.7×3	Basic wood crafts and electrical tools
1002A	Metal Shop	8.9×5.8×3	General welding facilities for repairs
1165	Costume Shop-01	5.9×10.2×3	Basic facilities for the maintenance of costume; Sewing machine, overlock machine and steam / iron equipment
1181	Costume Shop-02	5.8×11.8×3	
1163	Laundry Room-01	5.8×4.9×3	Washing machine, tumble dryers, sink and clothes folding table
B1019	Laundry Room-02	6×8.2×3	